

## Water-based primer for FEP topcoat (NC-2509).

### Overview

- NPW-1700C-6002 grade is a water-based primer for FEP topcoat (NC-2509).
- NPW-1700C-6002 makes a light brown primer layer displaying excellent adhesion to metal substrate.

### Basic characteristics

Film appearance	Viscosity [cP]	Solid content [mass%]	pH	Processable film thickness [ $\mu\text{m}$ ]
Light brown	100-400	38-45	4.0-7.0	30-50

### Coating procedure

#### 1.Pre-processing

This primer is a one-component product. It can be simply used by dispersing the contents before use.

Please note the following points

- Before using, please rotate the container for more than 30 minutes at a rotation speed of 30-50rpm.
- The product temperature should be room temperature. Please avoid stirring at high temperatures above 40°C.
- After dispersion, as needed filter with 80 mesh stainless steel wire before use.

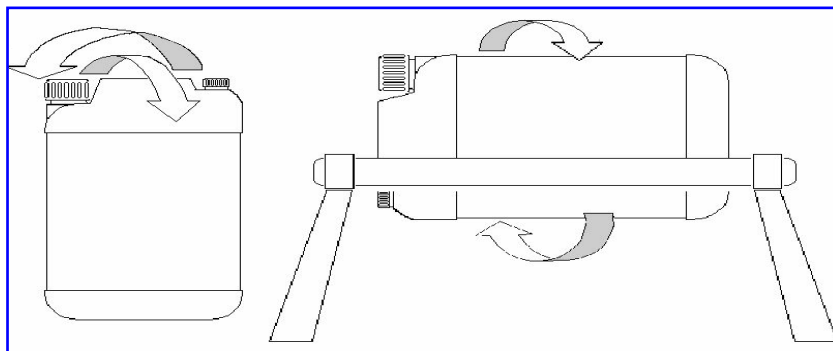

#### 2. Surface treatment of substrate

Thoroughly remove dirt and dust on the surface by baking or solvent degreasing. Please use sand blasting to roughen the substrate surface and perform blasting evenly so that the surface roughness (Ra) is more than 0.8 $\mu\text{m}$ ( In case of stainless steel).

#### 3.Applying primer

- Apply products by spray coating so that the film thickness (dry film thickness) is 30-50 $\mu\text{m}$ .
- Spray gun : aperture=0.8-1.5mm, Spray pressure=0.1-0.5MPa

#### 4. Drying primer

Please perform drying refer to below chart immediately after applying primer.

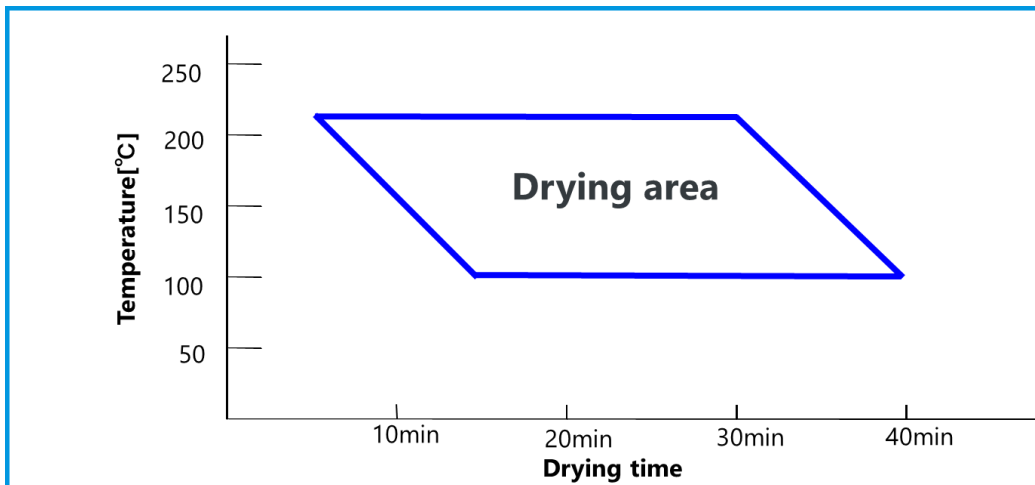

※ Notice for drying primer

- Insufficient drying condition will cause bubbling.
- Does not dry rapidly at 230°C or higher because it may contain bubbles in the coating.

#### 5. Applying top coat

Apply top coat after drying and cooling the primer layer, FEP coating powder can be used for the top coat (NC-2509). Please follow coating process of each top coat.

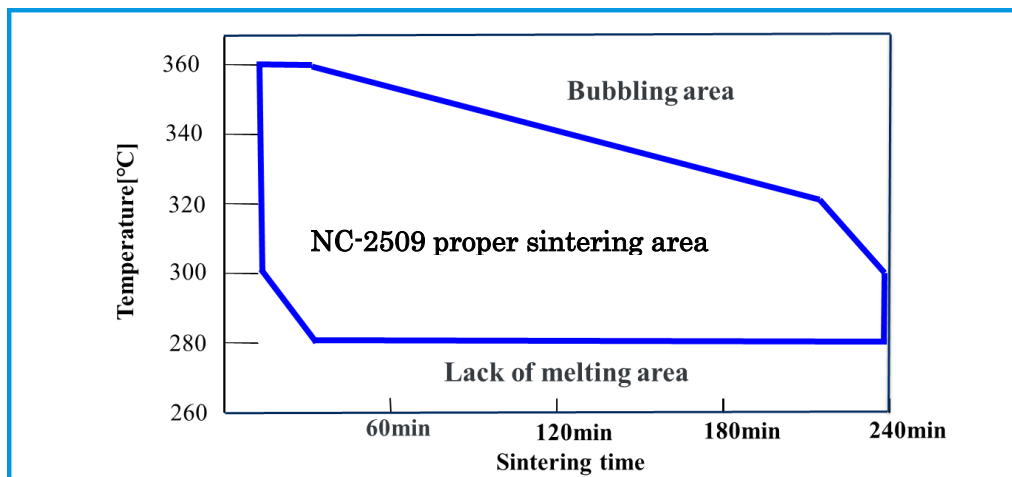

#### Handling method/Safety information

- Be sure to read the notes on SDS and labels before use.
- This product is not specifically designed or manufactured for use in implantable medical and/or dental devices. We have not tested it for such application and will only sell it for such use pursuant to contact containing specific terms and conditions required by us.

For more information, visit our website.

**DAIKIN INDUSTRIES, LTD.**

Chemicals Division <http://www.daikin.com/chm>

Global Locations <http://www.daikin.com/locations/business/chm/>